

Current exchange rate :
 CAD/US 1.33
 CAD/Euro 1.52

Color Code:

- CFI In-kind
- Red text: Un-costed / missing detail
- CFI requested

det M. 224
 # SM det. 28
 DOE Conti 0.2
 CFI Cont. 0.1

Legend:

- PP patch panel
- HPS HV power supply
- LPS LV power supply
- Det Detector
- TRK Traking
- INT Integrating
- PreA Preamplifier
- ADC Analog-to-digital converter
- PMT photo-multiplier tube
- Sig Signal
- Cntr Controller/Control

Integrating Detector Work Package Diagram

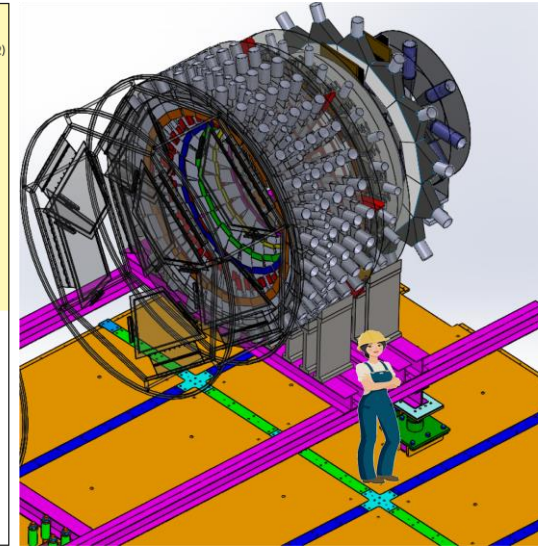
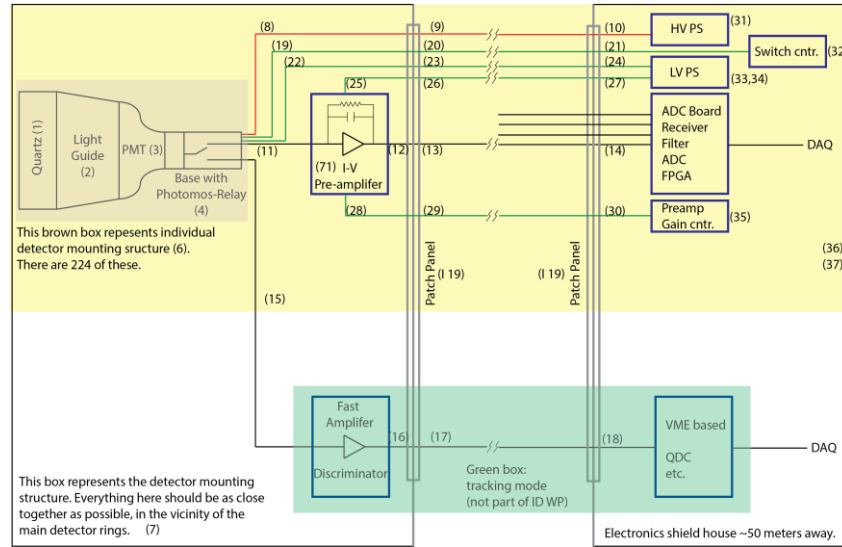

Thin Quartz Detectors										
Item	Part	Unit	Responsible Institution	Funding Source	Items	items	Cost/item \$US	Cost/item CAD	Total/part US\$	Total/part CAD
										W. 10% cont.
1	Quartz	num	UofM/SBU	CFI	224	246	1,200.00	1,596.00	295,200.00	392,616.00
2	Light guides	num	UofM/SBU	CFI	224	246	150.00	199.50	36,900.00	49,077.00
3	PMTs	num	UofM/SBU	CFI	224	246	1,500.00	1,995.00	369,000.00	490,770.00
4	Bases	num	UofM/SBU	CFI	224	246	300.00	399.00	73,800.00	98,154.00
5	Quartz assembly mounts	num	UofM/SBU	CFI	224	246	300.00	399.00	73,800.00	98,154.00
Subtotal equipment for thin detector modules only									848,700.00	1,128,771.00

Cables / Crates / Power Supplies / Control Units										
Item	Part	Unit	Responsible Institution	Funding Source	Items	items	Cost/item \$US	Cost/item CAD	Total/part US\$	Total/part CAD
										W. 20% cont.
6	HV cables PMT->PP	20 meter runs	JLab	DOE	252	302	110.00	146.30	33,220.00	44,182.60
7	HV cables PP->PP	5 meter runs	JLab	DOE	252	302	28.00	37.24	8,456.00	11,246.48
8	HV cables PP->PS	20 meter runs	JLab	DOE	252	302	110.00	146.30	33,220.00	44,182.60
9	Sig. cables (INT) PMT -> PreA	1 meter run	Jlab	DOE	252	302	8.00	10.64	2,416.00	3,213.28
10	Sig. cables (INT) PreA -> PP	20 meter runs	JLab	DOE	252	302	150.00	199.50	45,300.00	60,249.00
11	Sig. cables (INT) PP -> PP	5 meter runs	JLab	DOE	252	302	40.00	53.20	12,080.00	16,066.40
12	Sig. cables (INT) PP -> ADC	20 meter runs	JLab	DOE	252	302	150.00	199.50	45,300.00	60,249.00
13	Sig. cables (TRK) PMT -> PreA	1 meter run	Jlab	DOE	252	302	8.00	10.64	2,416.00	3,213.28
14	Sig. cables (TRK) PreA -> PP	20 meter runs	JLab	DOE	252	302	150.00	199.50	45,300.00	60,249.00
15	Sig. cables (TRK) PP -> PP	5 meter runs	JLab	DOE	252	302	40.00	53.20	12,080.00	16,066.40
16	Sig. cables (TRK) PP -> ADC	20 meter runs	JLab	DOE	252	302	150.00	199.50	45,300.00	60,249.00
17	Base Switch cables PMT -> PP	20 meter runs	JLab	DOE	252	302	105.00	139.65	31,710.00	42,174.30
18	Base Switch cables PP -> PP	5 meter runs	JLab	DOE	252	302	27.00	35.91	8,154.00	10,844.82
19	Base Switch cables PP -> Cntr.	20 meter runs	JLab	DOE	252	302	105.00	139.65	31,710.00	42,174.30
20	Base power cables PMT -> PP	20 meter runs	JLab	DOE	252	302	105.00	139.65	31,710.00	42,174.30
21	Base power cables PP -> PP	5 meter runs	JLab	DOE	252	302	27.00	35.91	8,154.00	10,844.82

22	Base power cables PP -> PS	20 meter runs	JLab	DOE	252	302	105.00	139.65	31,710.00	42,174.30
23	PreA power cables PMT -> PP	20 meter runs	JLab	DOE	252	302	105.00	139.65	31,710.00	42,174.30
24	PreA power cables PP -> PP	5 meter runs	JLab	DOE	252	302	27.00	35.91	8,154.00	10,844.82
25	PreA power cables PP -> PS	20 meter runs	JLab	DOE	252	302	105.00	139.65	31,710.00	42,174.30
26	PreA gain cntr. cbl. PMT -> PP	20 meter runs	JLab	DOE	252	302	105.00	139.65	31,710.00	42,174.30
27	PreA gain cntr. cbl. PP -> PP	5 meter runs	JLab	DOE	252	302	27.00	35.91	8,154.00	10,844.82
28	PreA gain cntr. cbl. PP -> Cntr.	20 meter runs	JLab	DOE	252	302	105.00	139.65	31,710.00	42,174.30
29	HV Power Supplies	24 ch. Boards	JLab	DOE	12	14	6,747.00	8,973.51	94,458.00	125,629.14
30	Base Switch Cntr. board(s)	channels	JLab	DOE	252	302	50.00	66.50	15,100.00	20,083.00
31	Base Switch PS	channels	JLab	DOE	252	302	400.00	532.00	120,800.00	160,664.00
32	Preamp and ADC PS	num	JLab	DOE	504	605	400.00	532.00	242,000.00	321,860.00
33	PreA gain Cntr. board(s)	channels	JLab	DOE	252	302	100.00	133.00	30,200.00	40,166.00
34	Electronics Crates	num	JLab	DOE	5	6	5,500.00	7,315.00	33,000.00	43,890.00
35	HV Mainframe	num	JLab	DOE	2	2	17,773.00	23,638.09	35,546.00	47,276.18
36	Patch panels + connectors	num	JLab	DOE	4	5	7,000.00	9,310.00	35,000.00	46,550.00
Subtotal all equipment for thin detectors w/o overall mounting structure									1,177,488.00	1,566,059.04

Shower Max Detectors										
Part	Unit	Responsible Institution	Funding Source	Items	items	Cost/item \$US	Cost/item CAD	Total/part US\$	Total/part CAD	
W. 20% cont.										
37	Quartz	num	ISU/SBU	DOE	124	149	1,200.00	1,596.00	178,800.00	237,804.00
38	PMTs	num	ISU/SBU	DOE	28	34	1,500.00	1,995.00	51,000.00	67,830.00
39	Bases	num	ISU/SBU	DOE	28	34	300.00	399.00	10,200.00	13,566.00
40	Light guides	num	ISU/SBU	DOE	28	34	100.00	133.00	3,400.00	4,522.00
41	Misc. Supplies and Mat.	arb.	ISU/SBU	DOE	28	28	50.00	66.50	1,400.00	1,862.00
42	Tungsten / Lead	num	ISU/SBU	DOE	124	149	650.00	864.50	96,850.00	128,810.50
43	Stack support frame	num	ISU/SBU	DOE	33	33	300.00	399.00	9,900.00	13,167.00
Subtotal equipment only									351,550.00	467,561.50

Integrating Electronics										
Part	Unit	Responsible Institution	Funding Source	Items	items	Cost/item \$US	Cost/item CAD	Total/part US\$	Total/part CAD	
W. 10% cont.										
44	ADC (INT)	channels	UofM/TRIUMF	CFI	484	532	250.00	332.50	133,000.00	176,890.00
45	Pre-amplifiers (INT)	channels	UofM/TRIUMF	CFI	224	246	200.00	266.00	49,200.00	65,436.00
Subtotal equipment only									182,200.00	242,326.00

Overall Mounting and Hall Infrastructure										
Part	Unit	Responsible Institution	Funding Source	Items	items	Cost/item \$US	Cost/item CAD	Total/part US\$	Total/part CAD	
W. 20% cont.										
46	Det. package mount	item	JLab	DOE	1	1	1,125,000.00	1,496,250.00	1,125,000.00	1,496,250.00
47	Hall modification	item	JLab	DOE	1	1	1,150,000.00	1,529,500.00	1,150,000.00	1,529,500.00
Subtotal equipment only									2,275,000.00	3,025,750.00

Overall Total (equipment only) **4,834,938.00** **6,430,467.54**

Personnel										
Part	Unit	Responsible Institution	Funding Source	Num of /yr	Num of yrs	Cost/year \$US	Cost/year CAD	Total/item US\$	Total/item CAD	
Or FTEs										
48	Undergraduate Students	#	UofM	NSERC	2	8		8,000.00		128,000.00
49	Undergraduate Students	#	UofW	NSERC	2	8		8,000.00		128,000.00
50	Undergraduate Students	#	Memorial	NSERC	2	8		8,000.00		128,000.00
51	Undergraduate Students	#	SBU	NSF	0	0	0.00			0.00
52	Undergraduate Students	#	SU	NSF	0	0	0.00			0.00
53	Undergraduate Students	#	ISU	NSF	0	0	0.00			0.00
54	Undergraduate Students	#	VT	NSF	0	0	0.00			0.00

55	Graduate Students	#	UofM	NSERC	6	12	21,000.00		1,512,000.00
56	Graduate Students	#	UofW	NSERC	2	12	21,000.00		504,000.00
57	Graduate Students	#	Memorial	NSERC	1	12	21,000.00		252,000.00
58	Graduate Students	#	SBU	NSF	0	0	0.00	0.00	
59	Graduate Students	#	SU	NSF	0	0	0.00	0.00	
60	Graduate Students	#	ISU	NSF	0	0	0.00	0.00	
61	Graduate Students	#	VT	NSF	0	0	0.00	0.00	
62	Research Associates (Postdocs)	#	UofM	NSERC	3	12	70,000.00		2,520,000.00
63	Research Associates (Postdocs)	#	UofW	NSERC	0	0	70,000.00		0.00
64	Research Associates (Postdocs)	#	Memorial	NSERC	0	0	70,000.00		0.00
65	Research Associates (Postdocs)	#	SBU	NSF	0	0	0.00	0.00	
66	Research Associates (Postdocs)	#	SU	NSF	0	0	0.00	0.00	
67	Research Associates (Postdocs)	#	ISU	NSF	0	0	0.00	0.00	
68	Research Associates (Postdocs)	#	VT	NSF	0	0	0.00	0.00	
69	Engineers	FTE	UofM	NSERC	0	0	100,000.00		0.00
70	Engineers	FTE	UofW	NSERC	0	0	100,000.00		0.00
71	Engineers	FTE	Memorial	NSERC	0	0	100,000.00		0.00
72	Engineers	FTE	SBU	NSF	0	0	0.00	0.00	
73	Engineers	FTE	SU	NSF	0	0	0.00	0.00	
74	Engineers	FTE	ISU	NSF	0	0	0.00	0.00	
75	Engineers	FTE	VT	NSF	0	0	0.00	0.00	
76	Technicians	FTE	UofM	NSERC	1	3	80,000.00		240,000.00
77	Technicians	FTE	UofW	NSERC	0	0	80,000.00		0.00
78	Technicians	FTE	Memorial	NSERC	0	0	80,000.00		0.00
79	Technicians	FTE	SBU	NSF	0	0	0.00	0.00	
80	Technicians	FTE	SU	NSF	0	0	0.00	0.00	
81	Technicians	FTE	ISU	NSF	0	0	0.00	0.00	
82	Technicians	FTE	VT	NSF	0	0	0.00	0.00	
83	Scientists	FTE	UofM	NSERC	0	0	100,000.00		0.00
84	Scientists	FTE	UofW	NSERC	0	0	100,000.00		0.00
85	Scientists	FTE	Memorial	NSERC	0	0	100,000.00		0.00
86	Scientists	FTE	SBU	NSF	0	0	0.00	0.00	
87	Scientists	FTE	SU	NSF	0	0	0.00	0.00	
88	Scientists	FTE	ISU	NSF	0	0	0.00	0.00	
89	Scientists	FTE	VT	NSF	0	0	0.00	0.00	
90	Technicians	FTE	TRIUMF	CFI	1	1	80,000.00		80,000.00
91	Engineers	FTE	TRIUMF	CFI	1	1	130,000.00		130,000.00
Subtotal									0.00 5,622,000.00
Total Manpower Only									0.00 5,622,000.00
Project Subsystem Total									12,052,467.54

CFI Request					
	Hardware				
			cost/module	modules	total
	Main Detector Quartz Module		\$4,588.50	246	\$1,128,771.00
	ADCs		\$332.50	532	\$176,890.00
	Preamps		\$266.00	246	\$65,436.00
				Subtotal	\$1,371,097.00
	Personnel				
			cost/month	months	total
	Engineer		\$10,833.33	12	\$130,000.00
	Technician		\$6,666.67	48	\$320,000.00

